

Series 4S

4-Pass Wetback Scotch Boiler



4-Pass Wetback Scotch Boiler

America's Boiler Company

The Burnham Commercial Series 4S four-pass wetback scotch boiler was designed using our 140+ years of boiler experience and is sold and serviced through the largest and most experienced network of sales representatives in the country. With a complete commercial product offering and unmatched sales and technical support, it's no wonder why we are America's Boiler Company!

Why Choose the Series 4S?

- The design incorporates positive water flow circulation and maximum heat transfer to maximize ratings.
- The handhole clean-outs are placed for ease of servicing.
- The access door is constructed of durable, lightweight vacuum formed ceramic fiber—the door liner weighs less than 40 pounds!
- All external trim piping is designed and installed in accordance with the ASME Code and is certified by an independent inspection agency for compliance.
- The fiberglass insulated aluminized steel jacket is finish painted with high gloss Burnham blue enamel.
- The front and rear full-sized hinged access doors are standard and secured with non-corrosive brass nuts.



- The UL approved packaged burners are trimmed and wired to assembled gas trains.
- The heavy steel base provides adequate stability along with shipping and rigging protection.
- It is completely packaged and ready for “same day” installation.
- The 5 sq.ft./hp rated design does not use turbulators or welded tube ends.
- The multitude of QC checkpoints and stringent final inspection assures you of a quality product.
- There are no proprietary parts or gaskets on the boiler trim or the burner.

Latest Design Techniques

The Series 4S uses the very latest design techniques and standards. Its furnace, the workhorse of the boiler, is designed for low volumetric release rates of no more than 130,000 btu/hr/cu.ft. The lower the release rates, the “easier” your boiler works. As your boiler works easier, less stress is put upon the steel, tube ends, refractory, etc., resulting in a longer lasting boiler. In addition to longevity, a larger furnace makes for ease in firing using any selected burner vendor. The Series 4S is also easily converted to a low NOx product when needed.

Higher Efficiency

The Burnham Series 4S design produces a higher efficiency due to the larger furnace and higher heat transfer design. To determine the efficiency of your next job, contact your local Burnham representative.

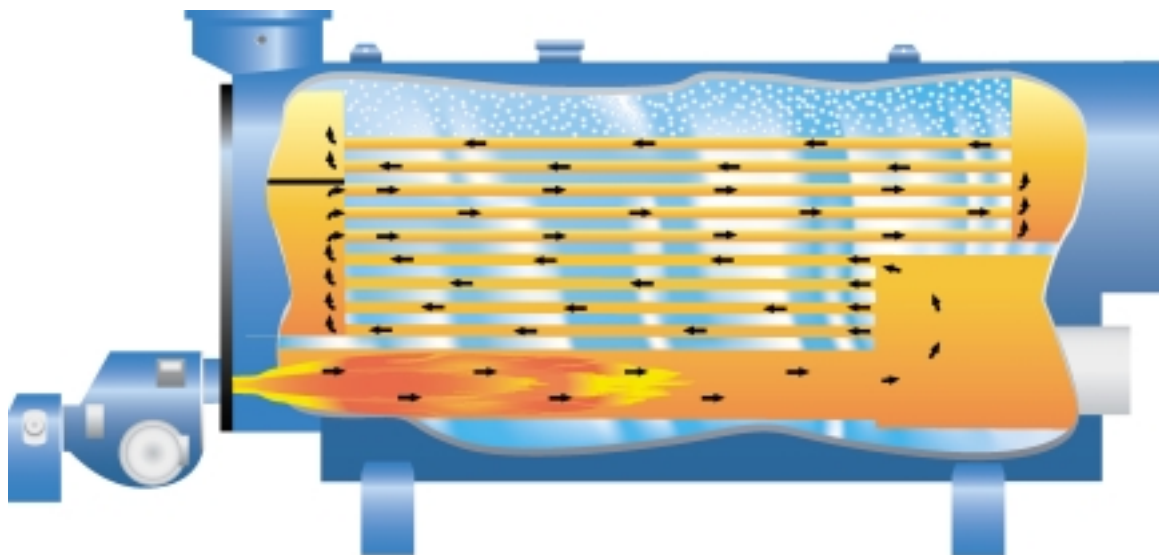

4 Pass Wetback Scotch Boiler—To learn more about wetback versus dryback, refer to our wetback literature

Dimensions

	100	125	150	175	200	250	300	350	400	500	600	700	800
A	68	68	76	76	76	84	84	94	94	104	104	114	114
B	84	85	93	93	93	101	101	111	111	121	121	131	131
C	150	176	169	188	207	205	233	240	263	264	300	286	315

Dimensions are approximate, see detailed drawings for more specific dimensions.

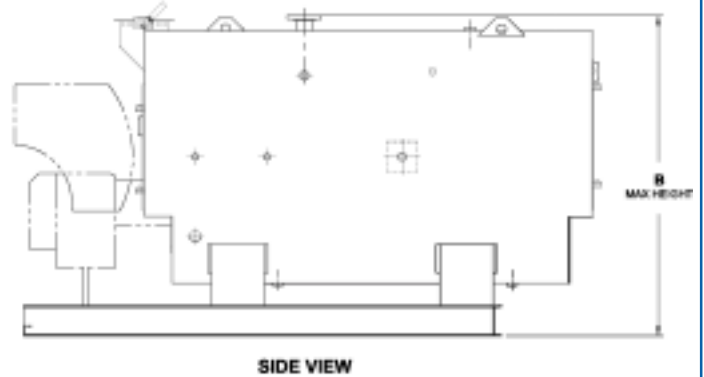
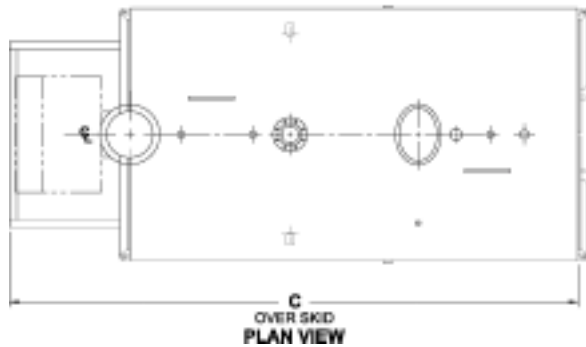
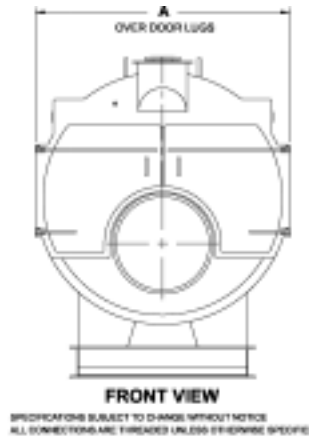

Rating Data

Boiler Size, HP	100	125	150	175	200	250	300	350	400	500	600	700	800
Shell Diameter	62	62	70	70	70	70	78	88	88	98	98	108	108
Gross Output, BHP	100	125	150	175	200	250	300	350	400	500	600	700	800
Gross Output, MBH	3348	4184	5021	5858	6695	8369	10,043	11,716	13,390	16,738	20,085	23,433	26,780
Gross Output, Lbs./Hr.	3450	4312.5	5175	6037.5	6900	8625	10,350	12,075	13,800	17,250	20,700	24,150	27,600
Heating Surface, FS Sq. Ft.	500	625	750	875	1000	1250	1500	1750	2000	2500	3000	3500	4000
Firing Rate — Gas													
Gas - MBH	4033	5041	6050	7058	8066	10,083	12,099	14,116	16,133	20,166	24,199	28,232	32,265
Oil - GPH (140 MBTU/Gal)	28	35	42	49	56	70	84	98	113	141	169	197	225
Furnace Volum — Cu. Ft.	39	46	58	66	73	93	108	133	149	177	206	226	253
Heat Releases Rate													
BTU/Hr./Cu. Ft.	103,728	108,613	104,551	107,532	109,882	108,547	111,993	106,035	108,425	114,244	117,272	124,878	127,527
Water Content													
Flooded - Gal.	875	1115	1187	1391	1606	1750	2110	2661	3045	3536	4256	4747	5431
NWL - Gal.	779	995	1019	1187	1367	1487	1786	2266	2601	2818	3405	3932	4507
Shipping Weight - Lbs.													
15/30 psi	8000	9400	10,500	12,000	13,200	15,600	18,300	22,300	24,500	28,900	33,200	38,300	42,500
125/150 psi	8900	10,400	11,700	13,200	14,400	18,600	21,600	25,000	27,600	32,300	37,100	45,100	50,000

Series 4S Standard Equipment

Boiler:

Four-pass full wetback firetube type, constructed in accordance with requirements of the ASME Code, Section IV for 30 PSI and 125 PSI water or 15 PSI steam; Section I for higher-pressure steam. All units are registered with the National Board.

Turbulator baffles are not used in tubes. Separate rear tube sheets allow safe expansion and contraction.

Waterbacked rear turnaround promotes rapid internal circulation and reduces gas temperatures at the entrance to the second pass, reducing tube end stress.

Easy opening hinged, insulated front flue doors with light weight non-refractory closure provide full access to all tubes. A light weight 16-inch diameter bolted rear access door with observation port provides access to the boiler furnace. Rear tube access is provided by removing lightweight gasketed doors(s) installed on the rear smokebox. No elaborate seals are used.

A manhole is furnished as standard. Handhole washouts are provided for easy inspection and cleaning of waterside surfaces.

All steam boilers are provided with a dry pan to ensure dry steam. A feedwater diffuser is provided on high-pressure boilers. All water boilers are equipped with a dip tube at supply outlet and diffuser at return inlet.

The round-flanged vertical smoke outlet is equipped with an aluminized quadrant damper. All boilers are provided with an enameled steel jacket installed over 2 inches of fiberglass insulation and lifting lugs.

The boiler is mounted on a heavy-duty structural steel base with extended skid and burner platform for protection of the burner during shipment and rigging.

Standard Trim and Controls:

Steam: 157 pump control/low water cut-off with alarm contacts—piped with quick opening blowoff valve. Gauge glass set with hand-operated gauge and try cocks. Steam pressure gauge—4 ½-inch dial on sizes 125 HP and smaller, 6-inch dial on larger sizes. L404A operating pressuretrol, L404C manual reset high limit pressuretrol and appropriate firing rate control when required. Manual reset probe auxiliary low water cut-off.

ASME side outlet safety valve(s).

Water: 63M manual reset low water cut-off with 30 PSI units, 150M low water cut-off with higher-pressure units—piped with quick opening blowoff valve. Combination pressure/temperature gauge—3 ½ inch dial on 125 HP and smaller. On larger sizes a 6-inch combination pressure/altitude gauge and 5-inch dial temperature gauge. L4006A operating aquastat and L4006E manual reset high limit aquastat and appropriate firing rate control when required.

ASME side outlet relief valve(s).

Burner Equipment:

Burner mounts directly to front head boiler with no elaborate seals.

Factory packaged units available with forced draft burners for all commonly used fuels—gas, all grades of oil—No. 2 through No. 6—a combination gas/oil. Choice of pressure or air atomizing burners for No. 2 oil—air-atomizing burners for No. 2 oil—air atomizing on heavy oil. Gas burners are available for either natural or LP gas.

Refer to burner data sheets for standard burner equipment and operating sequence.

Accessories and Optional Equipment:

Accessories and optional equipment available at extra cost, including, but not limited to:

- Alternate or additional water level controls or low water cut-offs
- Built-in tankless heater coils—low-pressure boilers only
- Motorized or pneumatic feed valves
- Surface skimmers and blowoff valves
- Bottom blowdown valves and drain valves
- Feed stop and check valves
- Sequence draft controls
- Lead/lag sequencing systems
- Boiler Feed systems
- Low NOx burners
- Deaerators
- Water Softeners
- Chemical Feed systems
- Blowdown systems
- Sample Coolers